

## Product Specification

SAP料号	SAP part No. :	10205F9828A10001A0
产品型号	Product P/N :	SK9828RGB-FC10WP4-H-000
样品号	SAP part No. :	/
客户料号	Client P/N :	/
版本号	Version No.:	A1
时间	Sending Date :	2025-04-03



## 目 录 Catalogue

1、产品概述 Overview .....	3
2、主要应用 Main applications .....	3
3、产品命名一般说明 General instructions for product naming .....	3
4、机械尺寸 Mechanical dimensions .....	4
5、引脚功能说明 Pin Function Description .....	4
6、PCB建议焊盘尺寸 PCB recommended pad size .....	5
7、IC极限参数 IC limit parameter .....	5
8、BRG LED光电参数 BRG LED Optoelectronic parameters .....	6
9、IC电气参数 IC electrical parameters .....	6
10、数据传输时间 Data transmission time .....	7
11、数据传输方式 Data transmission method .....	7
12、时序波形图 Time series waveform diagram .....	8
13、48bit数据结构 48 bit data structure .....	9-10
14、典型应用电路 Typical application circuit .....	11
15、光电特性 Photoelectric characteristic .....	12
16、包装标准 Packaging standards .....	13
17、可靠性测试 Reliability testing .....	14

## 1.产品概述 Product overview:

- 工作电压: 5V@0.4-3.2mA(OUT RGB) ;  
Forward voltage: 5V@0.4-3.2mA (OUT RGB) ;
- 发光角度: 160°;  
Luminescent angle: 160° ;
- 胶体颜色: 半透明;  
Lens color: translucent ;
- 内置复位电路, 上电不亮灯;  
Built-in reset circuit, power does not light ;
- 灰度调节: 65536级;  
Grayscale adjustment: 65536 levels ;
- 单线归零码传输协议, 可无限级联;  
Single-line zero code transmission protocol, can be infinite cascade;
- 湿敏等级: 2a ;  
MSL: 2a ;
- 静电ESD: 2KV;  
ESD level: 2KV;
- 符合RoHS REACH;  
RoHS and REACH-compliant;

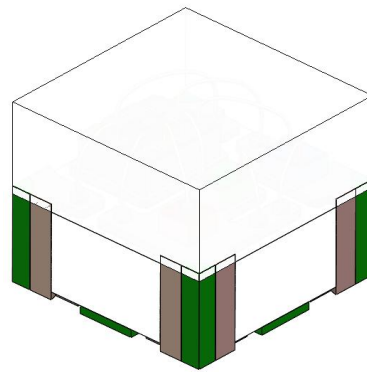

## 2.主要应用 Main applications:

- 消费电子产品  
Consumer electronics

## 3. 产品命名一般说明 General instructions for product naming:

### SK 9828 RGB-FC10 WP4-H-000

①      ②      ③      ④      ⑤      ⑥      ⑦

①	②	③	④	⑤	⑥	⑦
系列 Series	IC系列 IC series	色序 Color sequence	封装外形 Package outline	板材颜色 Board color	厚度 Thickness	内部编码 Internal code
默认为RGB晶片与IC集成在一起 Default to RGB chip integrated with IC	9828:指9828系列IC 9828: Refers to the 9828 series IC	R:红光 G:绿光 B:蓝光 R: Red light G: Green light B: Blue light	1.1x1.1x0.7毫米 PCB支架封装 1.1x1.1x0.7mm PCB holder packaging	W: 表示白色 P4:四脚 W: Indicates white P4:4-pin	H: 表示厚度0.9MM H: Indicates thickness of 0.9MM	000: 流水码 000: Serial code

## 4.机械尺寸 Mechanical dimensions:

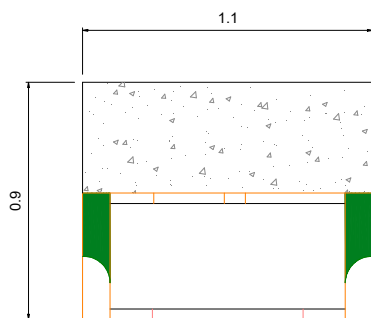
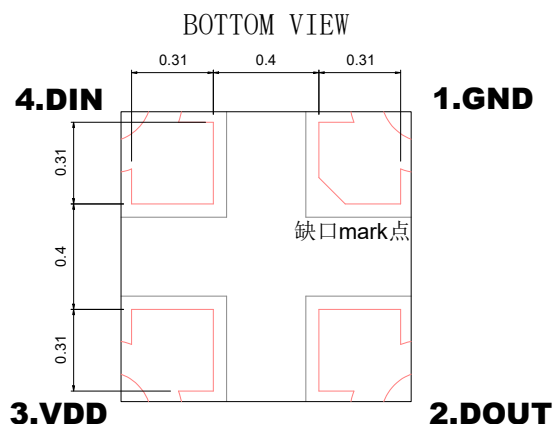
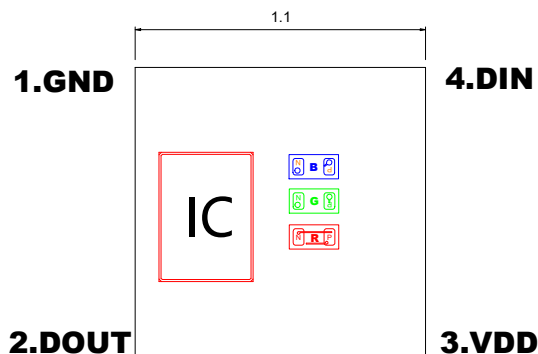

### 备注 Notes:

1. 以上标示单位为毫米.  
The above markings are in millimeters
2. 除非另外注明, 尺寸公差为  $\pm 0.1$ 毫米.  
Unless otherwise specified, the dimensional tolerance is  $\pm 0.1$  millimeters

## 5. 引脚功能说明 Pin Function Description:

序号 Serial Number	符号 Symbol	管脚名 Pin name	功能描述 Function Description
1	GND	地 Grounds	电源接地 Power grounding
2	DOUT	数据输出 Data output	控制数据信号输出 Control data signal output
3	VDD	电源 Power supply	供电管脚 Power supply pins
4	DIN	数据输入 Data input	控制数据信号输入 Control data signal input

## 6.PCB建议焊盘尺寸 PCB recommended pad size:

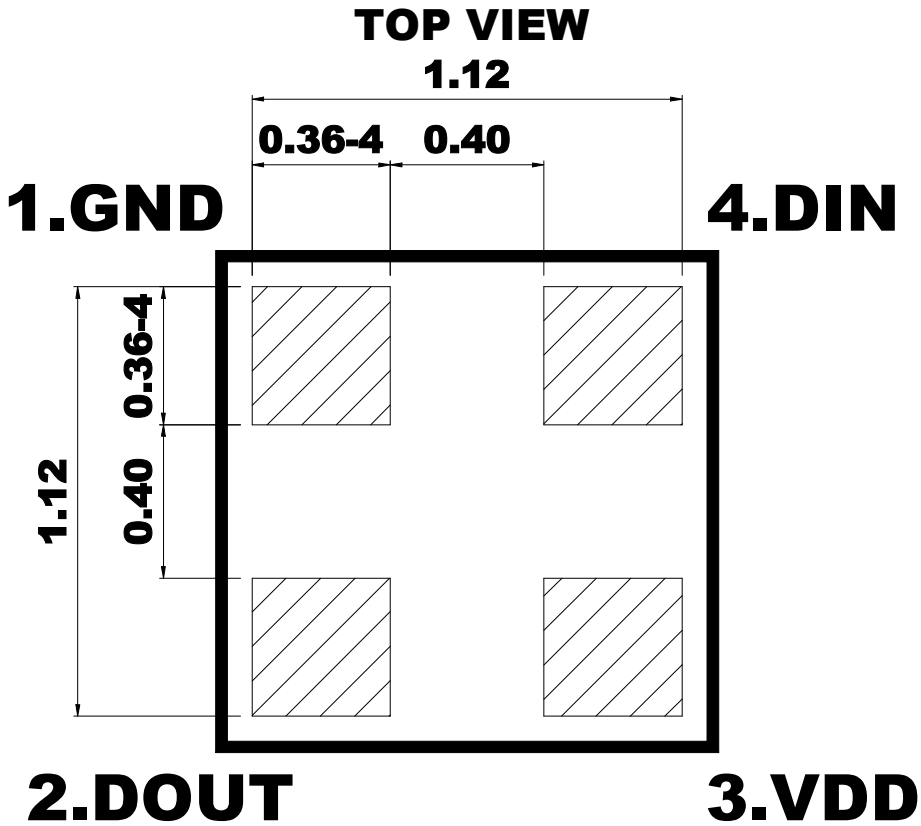

## 7.IC极限参数 IC limit parameter : (Ta=25°C)

参数 Parameter	符号 Symbol	范围 Range	单位 Unit
逻辑电源电压 Working voltage	V <sub>DD</sub>	+3.7~+5.5	V
工作温度 Operation temperature	T <sub>opt</sub>	-40~+85	°C
储存温度 Storage temperature	T <sub>stg</sub>	-40~+85	°C
ESD耐压 (人体模式) ESD withstand voltage (human mode)	V <sub>ESD</sub>	2K	V

## 8. BRG LED 光电参数 Optoelectronic parameters:

颜色 Colour	SK9828RGB-FC10WP4-H-000 3.2mA	
	波长 (nm) Wavelength (nm)	亮度 (mcd) Brightness (mcd)
红色 (RED)	618-623	30-60
绿色 (GREEN)	525-535	120-240
蓝色 (BLUE)	460-470	15-30

## 9. IC电气参数 IC electrical parameters: (TA=25°C)

参数 Parameter	符号 Symbol	最小 Minimum	典型 Typical	最大 Maximum	单位 Unit	测试条件 Test conditions
工作电压 Chip input voltage	VDD	3.7	5	5.5	V	---
信号输入翻转阈值 Signal input flip threshold	VIH	0.65*VDD	---	---	V	VDD=5V, DIN 输入高电平 VDD=5V, DIN high level input
	VIL	---	---	0.28*VDD	V	VDD=5V, DIN 输入低电平 VDD=5V, DIN low level input
R/G/B输出驱动电流 R/G/B output drive current	I <sub>DOUT</sub>	0.4	3.2	---	mA	V <sub>DS</sub> =1V
PWM频率 PWM frequency	F <sub>PWM</sub>	---	8	---	KHz	---
静态功耗 Static power consumption	I <sub>DD</sub>	---	0.23	---	mA	VDD=5V,RGB灰 阶设置为0 VDD=5V,RGB grayscale set to 0
数据传输速率 Transfer rate	F <sub>DIN</sub>	---	1500	---	Kbps	---

## 10. 建议数据传输时间 Suggested data transmission time:

时序表名称 Timeline Name	Min.	实际值 Actual value	Max.	单位 Unit
T	码元周期 Symbol period	0.65	---	us
T0H	0码, 高电平时间 0 code, high-level time	0.18	0.20	us
T0L	0码, 低电平时间 0 code, low-level time	0.43	0.45	us
T1H	1码, 高电平时间 1 code, high-level time	0.43	0.45	us
T1L	1码, 低电平时间 1 code, low-level time	0.18	0.20	us
Reset	Reset码, 低电平时间 Reset code, low-level time	>300	--	us

- 上述为 MCU 输出通信协议时间要求, 码元周期最低要求为 0.65us;
- 0 码、1 码的高电平时间需按照上表的规定范围, 0 码、1 码的低电平时间要求小于 20us

## 11. 数据传输方式 Data transmission method: (Ta=25°C)

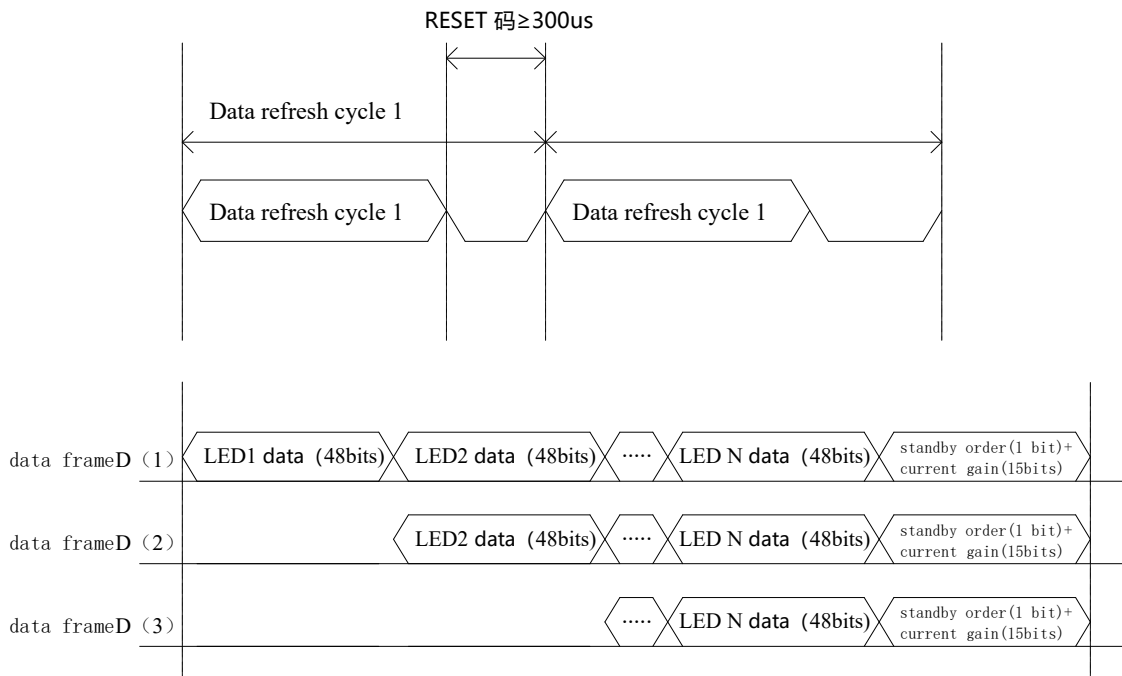

注: 其中D1为MCU端发送的数据, D2、D3、Dn为级联电路自动整形转发的数据。

Note: D1 represents the data sent by the MCU end, and D2, D3, and Dn represent the data automatically shaped and forwarded by the cascaded circuit.

## 12.时序波形图 Time series waveform diagram: (Ta=25°C)

输入码型 Input code type:

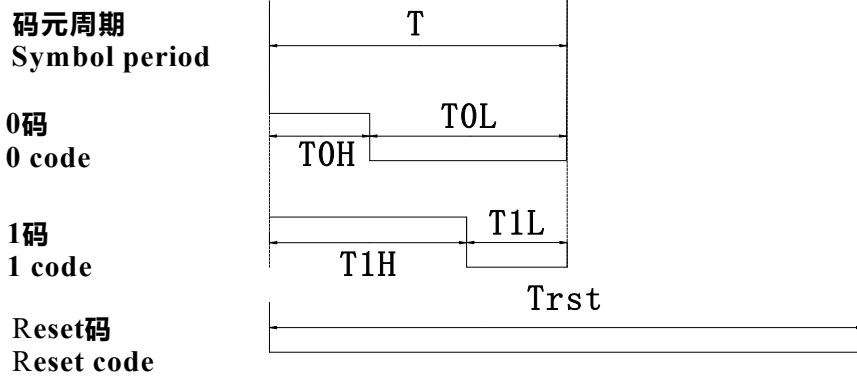

连接方式 Connection method:

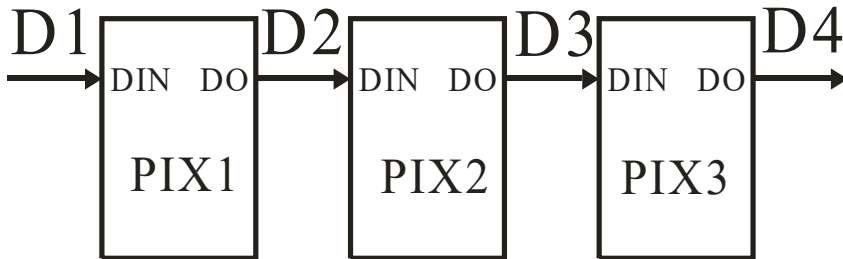

## 13. 48bit数据结构 48 bit data structure: (Ta=25°C)

R15	R14	R13	R12	R11	R10	R9	R8	R7	R6	R5	R4	R3	R2	R1	R0
G15	G14	G13	G12	G11	G10	G9	G8	G7	G6	G5	G4	G3	G2	G1	G0
B15	B14	B13	B12	B11	B10	B9	B8	B7	B6	B5	B4	B3	B2	B1	B0

注：高位先发，按照RGB的顺序发送数据(R15 → R14 →.....B0)

Note: High bit first send, send data in RGB order (R15 → R14 →..... B0)

第一颗芯片48bits数据+第二颗芯片48bits数据+.....+第N颗芯片48bits数据+1bit待机指令+15bit电流增益数据

• 48bits 灰度数据结构：高位在前，按照RGB的顺序发送

First chip 48bit data+second chip 48bit data+...+Nth chip 48bit data+1bit standby order+15bit current gain data

48bit grayscale data structure: high bits first, sent in RGB order

S0	GR4	GR3	GR2	GR1	GR0	GG4	GG3	GG2	GG1	GG0	GB4	GB3	GB2	GB1	GB0
----	-----	-----	-----	-----	-----	-----	-----	-----	-----	-----	-----	-----	-----	-----	-----

### 电流增益调节参数：

Current gain adjustment parameters:

电流增益数据共16bits,S0 为待机指令位：芯片正常工作时，S0 默认发送 0；芯片需进入待机休眠模式时，S0 发送 1；红绿蓝灯电流增益调节位各5bits,分别对应5bits(GR4~GR0),系统发送顺序是先发红灯5bits,然后是绿灯的5bits,再发蓝灯的5bits,先发高位GG4,最后发低位GB0.

The current gain data is 16 bits, with S0 being the standby command bit: S0 defaults to sending 0 when the chip operating normally; S0 sends 1 when the chip needs to enter standby sleep mode. The current gain adjustment bits for the red, green, and blue lights each 5 bits, corresponding to 5 bits (GR4~GR0). The system sends the data in the order of red light 5 bits first then green light 5 bits, and finally blue light 5 bits. It starts with the high bit GR4 and ends with the low bit GB0

电流增益参数发送格式 Current gain parameter sending format			
待机指令	红灯 (R)	绿灯 (G)	蓝灯 (B)
S0	GR4 , GR3 , GR2,GR1 , GR0	GG4 , GG3 , GG2,GG1 , GG0	GB4 , GB3 , GB2,GB1 , GB0

OUTG/R/B 最大输出电流典型值为：3.2mA，同时用户可通过改变电流增益数值设置其他电流值，参考电流值请参考下表：

The maximum output current typical value of OUTG/R/B is 3.2mA, while users can set other current values by changing the current gain. Please refer to the following table for the reference current values:

电流调节等级 Current regulation level	对应电流值 (mA) Corresponding current value (mA)
00000	0.4
00001	0.8
00010	1.2
00011	1.6
00100	2.0
00101	2.4
00110	2.8
00111	3.2

注：以上电流值仅为理论数据，实际电流可能有偏差，建议客户调节电流值以实测为准

Note: The above current values are only theoretical data, and there may be deviations in actual current. It is recommended that customers adjust the current values based on actual measurements

1、建议使用电流：3.2mA电流等级。 Suggested use of current: 3.2mA current level

2、基于产品散热，此款产品电流建议最大使用为：3.2mA

Based on product heat dissipation, the recommended maximum current for this product is 3.2mA

## 14.应用电路原理图 Principles of Applied Circuits:

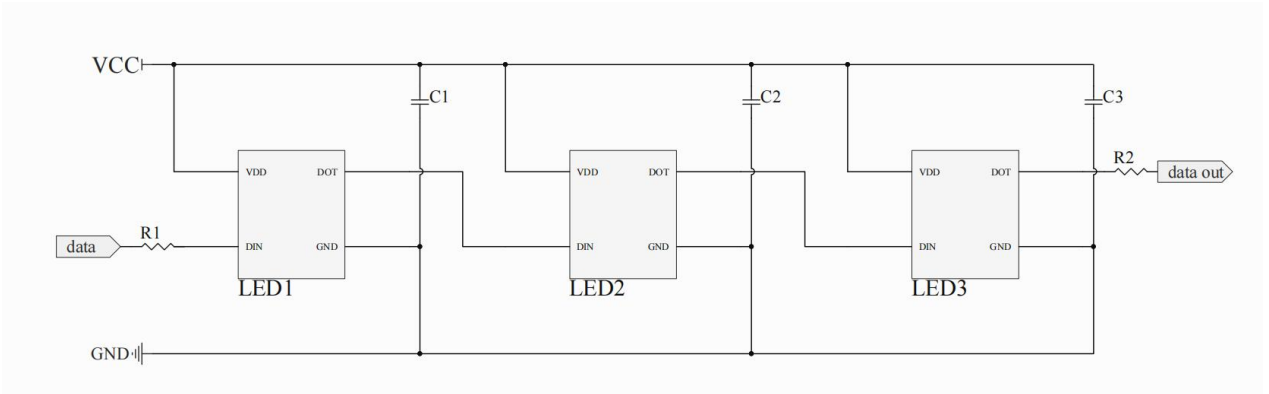

在实际应用电路中，为防止产品在测试时带电插拔产生的瞬间高压损伤IC内部信号输入输出引脚，应在信号输入及输出端串接保护电阻。此外，为了使各IC芯片间更稳定工作，各灯珠间的退偶电容则必不可少；

- 1.应用一：用于软灯灯或硬灯条的，灯珠间传输距离短的，建议在信号输入输出端各串接保护电阻，即 $R1=R2$ 约500欧；
- 2.应用二：用于模组或3.一般异形产品，灯珠间传输距离长，因线材及传输距离不同，在信号两端串接的保护电阻会略有不同；以实际使用情况定；

In practical application circuits, to prevent instantaneous high voltage damage to the internal signal input and output pins of the IC caused by live plugging and unplugging during testing, protective resistors should be connected in series at the signal input and output terminals. In addition, in order to ensure more stable operation between IC chips, the decoupling capacitance between each LED is essential;

1. Application 1: For soft or hard light strips with short transmission distance between lamp beads, it is recommended to connect protective resistors in series at the signal input and output terminals, that is,  $R1=R2$ , about 500 ohms;
2. Application 2: Used for modules or 3. For general shaped products, the transmission distance between lamp beads is long. Due to different wire materials and transmission distances, the protective resistance connected in series at both ends of the signal will be slightly different; Based on actual usage;

## 15. 光电特性 Photoelectric characteristic:

焊盘温度与光通量输出的相对关系  
The relative relationship between pad temperature and luminous flux output

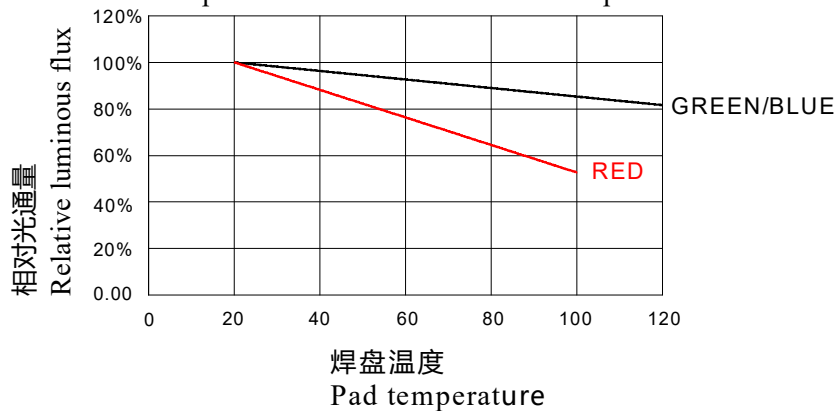

波长特性  
Wavelength characteristics

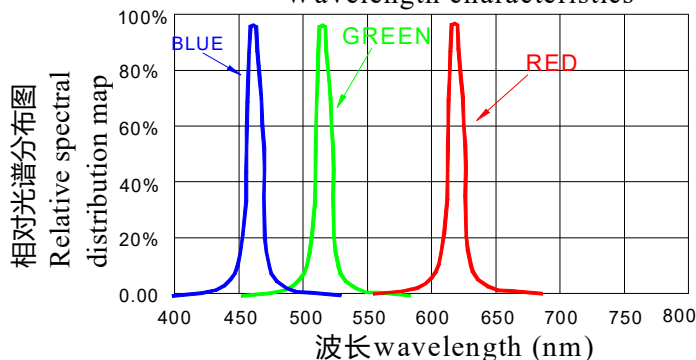

典型的辐射方向图 160°  
Typical radiation pattern 160°

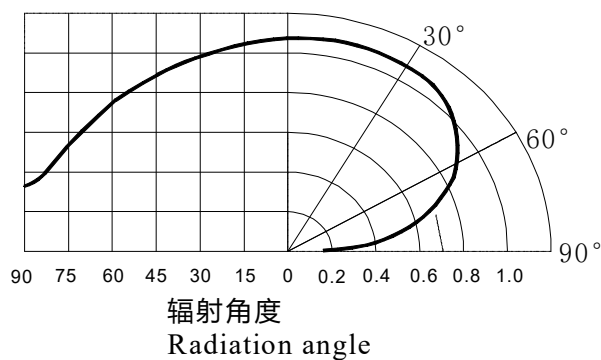

## 16. 包装标准 Packaging standards:

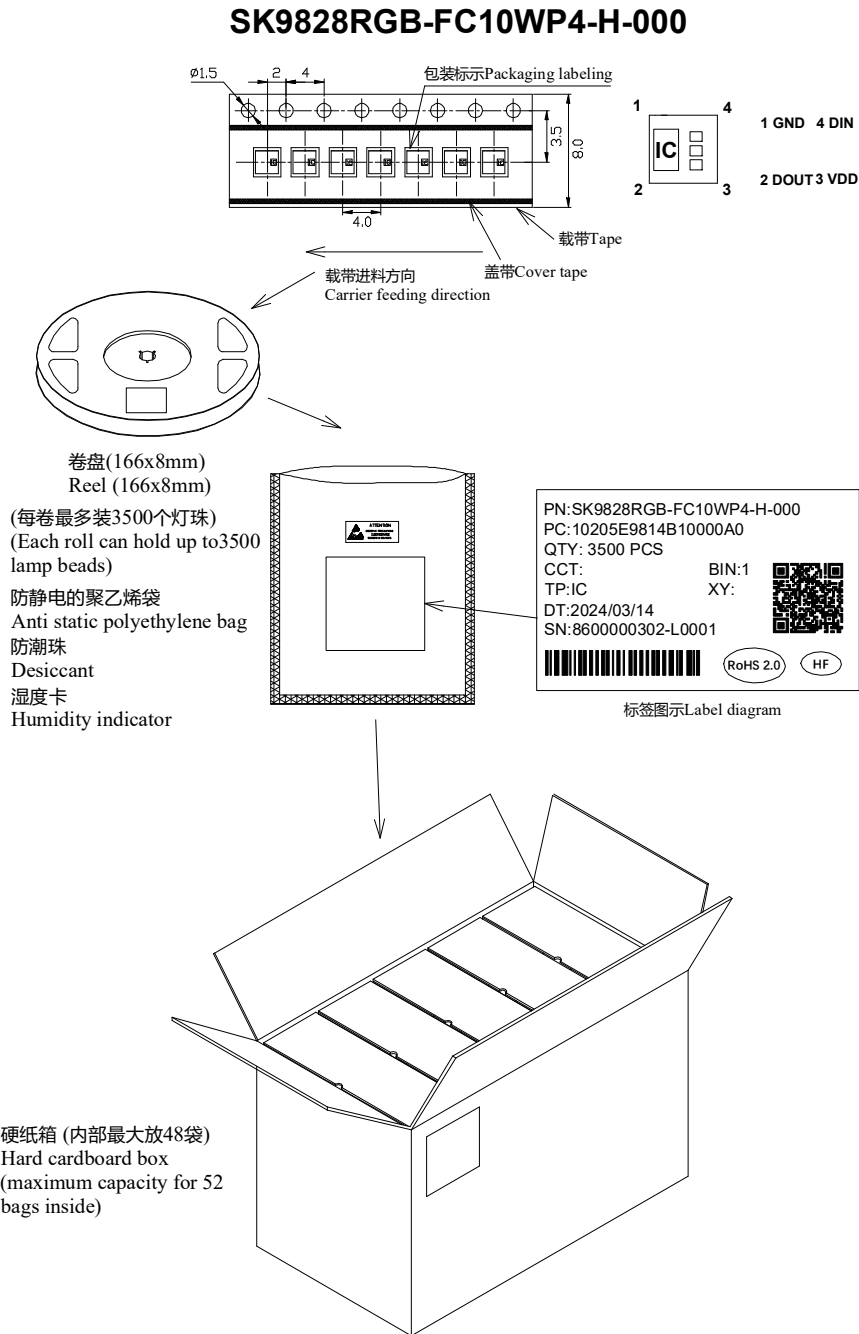

表面贴装LED采用卷盘包装，LED在用普通或防静电袋包装后再装在纸箱中。纸箱用于保护运输途中LED不受机械冲击，纸箱不防水，因此请注意防潮防水。

Surface mounted LEDs are packaged in rolls, and the LEDs are packaged in regular or anti-static bags before being packed in cardboard boxes. The cardboard box is used to protect the LED from mechanical impact during transportation. The cardboard box is not waterproof, so please pay attention to moisture-proof and waterproof.

## 17. 可靠性测试 Reliability testing:

序号 Serial Number	实验项目 Pilot projects	实验条件 Experimental condition	参考标准 Reference standards	判断 Determine
1	冷热冲击 Thermal Shock	100 ± 5°C ~ -40°C ± 5°C 15min~15min 100cycles	MIL-STD-202G	0/22
2	高温储藏 High temperature storage	Ta= +100°C 1000hrs	JEITA ED-4701 200 201	0/22
3	低温储藏 Low temperature storage	Ta= -40°C 1000hrs	JEITA ED-4701 200 202	0/22
4	高温高湿储藏 High temperature and high humidity storage	Ta=60°C RH=90% 1000hrs	JEITA ED-4701 100 103	0/22
5	温度循环 Temperature cycling	-40°C~25°C~100°C~25°C 30min~5min~30min~5min 100 cycles	JEITA ED-4701 100 105	0/22
6	耐焊接热 Resistance to Soldering Heat	Tsld = 260°C, 10sec. 2 times	JEITA ED-4701 300 301	0/22
7	常温寿命测试 Normal temperature life test	25°C, IF: Typical current , 1000hrs	JESD22-A 108D	0/22

## 失效判定标准 Failure criteria:

项目 Project	符号 Symbol	测试条件 Test conditions	判断标准 Judgment criteria	
			最小值 Minimum value	最大值 Maximum value
发光强度 Intensity	IV	DC=5V,规格典型电流 DC=5V, typical current specification	初始数据X0.7 Initial data X0.7	---
耐焊接热 Resistance to Soldering Heat	---	DC=5V,规格典型电流 DC=5V, typical current specification	无死灯或明显损坏 No dead lights or obvious damage	

