

## Product Specification

SAP料号	SAP part No. :	10201T9828B22005A0
产品型号	Product P/N :	SK9828MICROX-D-B2-001
样品号	SAP part No. :	NMD000298-018
客户料号	Client P/N :	NA
版本号	Version No. :	A/0
时间	Sending Date :	2025-06-17



## 目 录 Catalogue

1、产品概述 Overview .....	3
2、主要应用 Main applications .....	3
3、产品命名一般说明 General instructions for product naming .....	3
4、机械尺寸 Mechanical dimensions .....	4
5、引脚功能说明 Pin Function Description .....	4
6、PCB建议焊盘尺寸 PCB recommended pad size .....	5
7、IC极限参数 IC limit parameter .....	5
8、BGR LED光电参数 BGR LED Optoelectronic parameters .....	5
9、IC电气参数 IC electrical parameters .....	6
10、数据传输时间 Data transmission time .....	7
11、数据传输方式 Data transmission method .....	7
12、时序波形图 Time series waveform diagram .....	8
13、48bit数据结构 48 bit data structure .....	8-9
14、典型应用电路 Typical application circuit .....	10
15、光电特性 Photoelectric characteristic .....	10
16、包装标准 Packaging standards .....	11
17、可靠性测试 Reliability testing .....	12

# Shenzhen Normand Electronic Co.,Ltd

## 1.产品概述 Product overview:

- 工作电压：5V@0.4-13mA(OUT GRB)；

Forward voltage: 5V@0.4-13mA (OUT GRB) , ;

- 发光角度：120°；

Luminescent angle: 120° ；

- 胶体颜色：半透明；

Lens color: translucent ；

- 内置复位电路，上电不亮灯；

Built-in reset circuit, power does not light ；

- 灰度调节：65536级；

Grayscale adjustment：65536 levels ；

- 单线归零码传输协议，可无限级联；

Single-line zero code transmission protocol, can be infinite cascade ；

- 数据传输频率可达1500Kbps，当刷新速30帧/秒时，级联数小于1024点；

The data transmission frequency can reach 1500Kbps, and when the refresh speed is 30 frames per second, the cascade number is less than 1024 points. ；

- 湿敏等级：5a ；

MSL：5a ；

- 静电ESD：2KV ；

ESD level: 2KV ；

- 符合RoHS REACH ；

RoHS and REACH-compliant ；

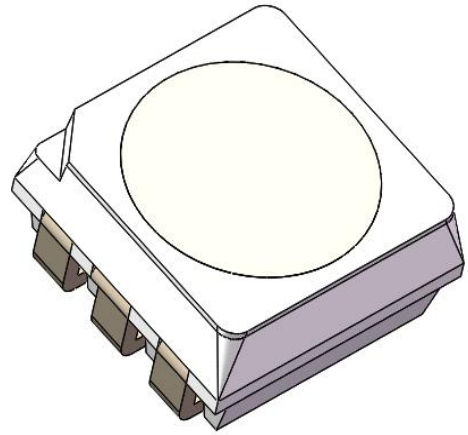

## 2.主要应用 Main applications:

- 显示屏产品

Display screen products

## 3. 产品命名一般说明 General instructions for product naming：

SK 9828-MICROX-D-B2-001

① ② ③ ④ ⑤

①	②	③	④	⑤
系列 Series	IC系列与电流代码 IC series and current codes	封装外形 Package outline dimensions	胶体颜色代码 Lens color code	内部编码 Internal code
默认为RGB晶片与 IC集成在一起 Default to RGB chip integrated with IC	9828:指9828系列IC,0.4-13mA 可调电流 Refers to the 9828 series IC,0.4- 13mA(adjustable current)	MICROX:指封装尺寸为 2.2*2.2*1.05mm The package size is 2.2 * 2.2*1.05mm	D:雾状胶体 Diffused lens	B2-001:内部 编码 Internal code

## 4.机械尺寸 Mechanical dimensions:

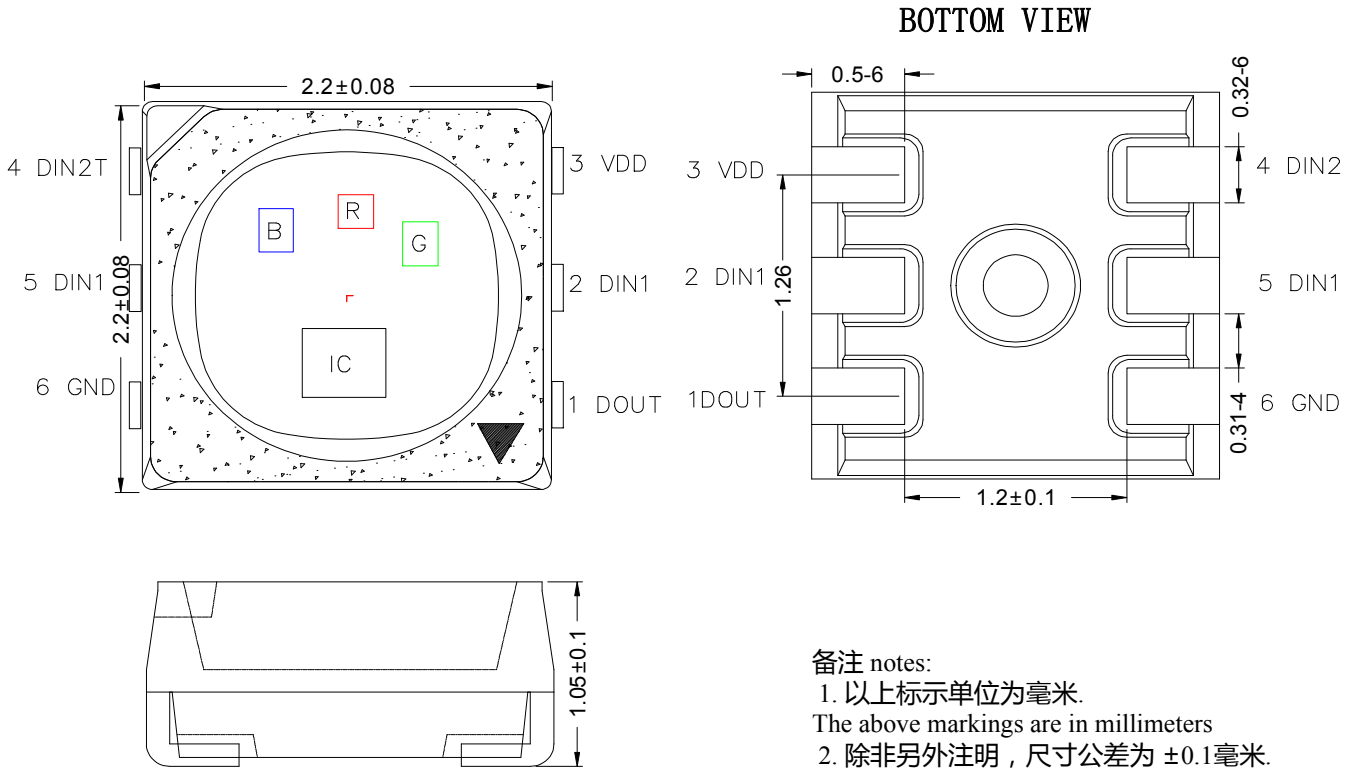

备注 notes:

1. 以上标示单位为毫米。  
The above markings are in millimeters
2. 除非另外注明，尺寸公差为  $\pm 0.1$  毫米。  
Unless otherwise specified, the dimensional tolerance is  $\pm 0.1$  millimeters

## 5. 引脚功能说明 Pin Function Description :

序号 Serial number	符号 Symbol	管脚名 Pin name	功能描述 Function description
1	DOUT	数据输出 Data output	控制数据信号输出 Control data signal output
2	DIN1	数据输入 Data input	控制数据信号输入 Control data signal input
3	VDD	电源 Power supply	供电管脚 Power supply pins
4	DIN2	热数据处理 Thermal data processing	热数据信号处理 Thermal data signal processing
5	DIN1	数据输入 Data input	控制数据信号输入 Control data signal input
6	GND	地 Grounds	电源接地 Power grounding

# Shenzhen Normand Electronic Co.,Ltd

## 6.PCB建议焊盘尺寸 PCB recommended pad size :

### TOP VIEW

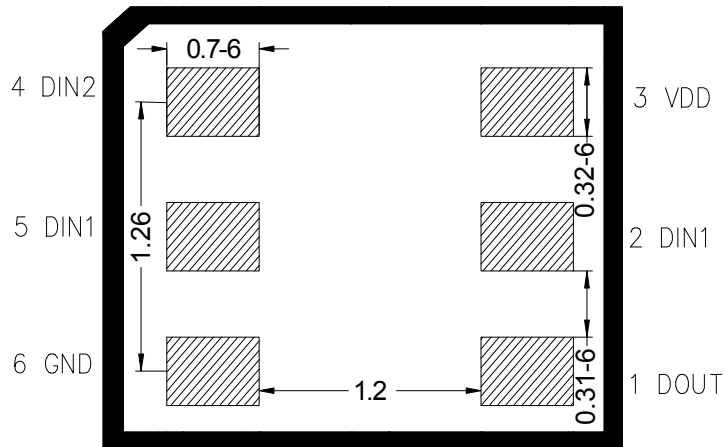

## 7.IC极限参数 IC limit parameter : ( Ta=25°C )

参数 Parameter	符号 Symbol	范围 Range	单位 Unit
逻辑电源电压 Working voltage	$V_{DD}$	+3.5 ~ +5.5	V
工作温度 Operation temperature	$T_{opt}$	-40 ~ +80	°C
储存温度 Storage temperature	$T_{stg}$	-40 ~ +80	°C
ESD耐压 ( 人体模式 ) ESD withstand voltage (human mode)	$V_{ESD}$	2K	V

## 8. BGR LED 光电参数 Optoelectronic parameters :

颜色 Colour	SK9828MICROX-D-B1-001 3.2MA	
	波长 ( nm ) Wavelength ( nm )	亮度 ( mcd ) Brightness ( mcd )
红色 ( RED )	615-625	35-70
绿色 ( GREEN )	525-535	140-280
蓝色 ( BLUE )	465-475	35-70

注：亮度误差±10%，波长误差±1.0nm;

Note:Luminous Intensity: ±10%Iv, Dominant Wavelength: ±1.0nm.

# Shenzhen Normand Electronic Co.,Ltd

## 9. IC电气参数 IC electrical parameters : ( TA=25°C )

参数 Parameter	符号 Symbol	最小 Minimum	典型 Typical	最大 Maximum	单位 Unit	测试条件 Test conditions
工作电压 Chip input voltage	VDD	3.5	---	5.5	V	---
信号输入翻转阈值 Signal input flip threshold	VIH	0.65*VDD	---	---	V	DIN 输入高电平 DIN input high level
	VIL	---	---	0.3*VDD	V	DIN 输入低电平 DIN input low level
B/G/R输出驱动电流 B/G/R output drive current	I <sub>DOUT</sub>	0.4	---	13	mA	V <sub>DS</sub> =1V
静态功耗 Static power consumption	I <sub>DD</sub>	---	0.23	---	mA	VDD = 5V , IOUT ”OFF”
待机电流 Standby current	I <sub>DD_STB</sub>	---	---	1	uA	发送待机数据 Send standby data
数据传输速率 Transfer rate	F <sub>DIN</sub>	---	1500	---	Kbps	---
OUT R/G/B输出PWM频率 OUT R/G/B PWM frequency	FPWM	---	8.0	---	KHZ	DOUT 端口对地 负载电容30pF , DIN 至DOUT 的 信号传输延时 The DOUT port has a ground load capacitance of 30pF,Signal transmission delay from DIN to DOUT

## 10. 建议数据传输时间 Suggested data transmission time :

时序表名称 Timeline name		Min.	实际值 Actual value	Max.	单位 Unit
T	码元周期 Symbol period	0.65	---	---	us
T0H	0码, 高电平时间 0 code, high-level time	0.15	0.20	0.25	us
T0L	0码, 低电平时间 0 code, low-level time	0.45	---	---	us
T1H	1码, 高电平时间 1 code, high-level time	0.45	0.50	0.55	us
T1L	1码, 低电平时间 1 code, low-level time	0.20	---	---	us
Reset	Reset码, 低电平时间 Reset code, low-level time	>300	---	---	us

## 11. 数据传输方式 Data transmission method : ( Ta=25°C )

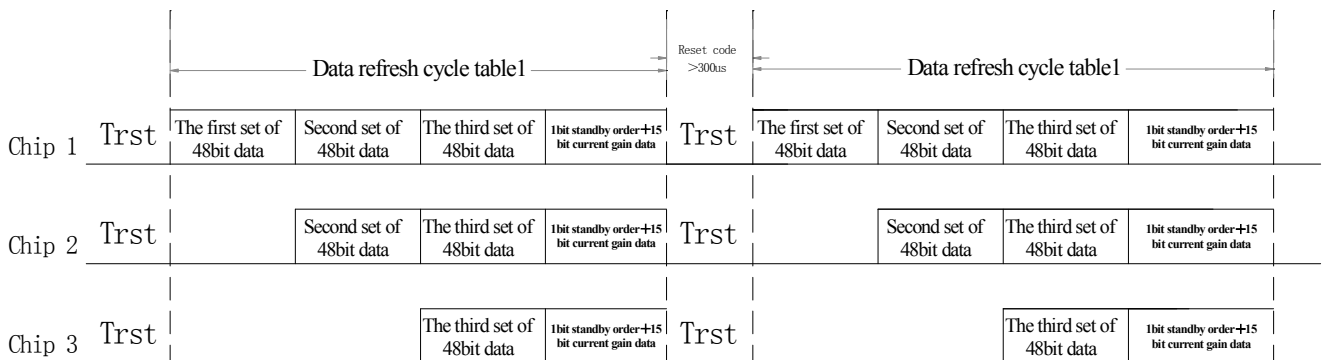

## 12.时序波形图 Time series waveform diagram : ( Ta=25°C )

输入码型Input code type:

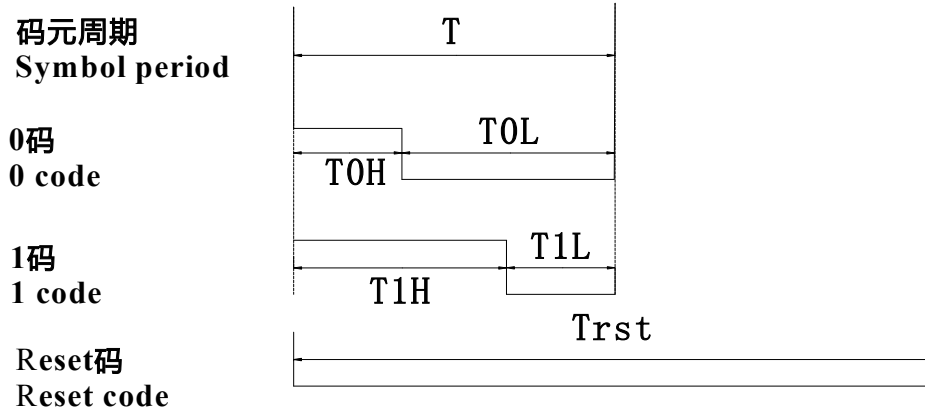

## 13. 48bit数据结构 48 bit data structure : ( Ta=25°C )

B15	B14	B13	B12	B11	B10	B9	B8	B7	B6	B5	B4	B3	B2	B1	B0
R15	R14	R13	R12	R11	R10	R9	R8	R7	R6	R5	R4	R3	R2	R1	R0
G15	G14	G13	G12	G11	G10	G9	G8	G7	G6	G5	G4	G3	G2	G1	G0

注：高位先发，按照GRB的顺序发送数据(B15 → B14 →.....G0)

Note: High bit first send, send data in GRB order (B15 → B14 →.... G0)

Trst+第一颗芯片48bits数据+第二颗芯片48bits数据+.....+第N颗芯片48bits数据+1bit待机指令 + 15bits电流增益数据+Trst  
 Trst+48bit data from the first chip+48bit data from the second chip+...+48bit data from the Nth chip+1bit standby order + 15bit current gain data+Trst

- 48bits 灰度数据结构：高位在前，按照BRG的顺序发送  
 48bit grayscale data structure: high bits first, sent in BRG order

B15	B14	B13	B12	B11	B10	B9	B8	B7	B6	B5	B4	B3	B2	B1	B0	R15.....R0	G15...G0
Bit48.....																bit0	

- 系统拓扑图System topology diagram :



# Shenzhen Normand Electronic Co.,Ltd

电流增益调节参数Current gain adjustment parameters :

电流增益数据共 15bits，此款产品支持软件设定OUT输出端的电流，其中包含OUT B/R/G端口各5bits 电流增益数据和1bit 保留位数据，15bits 电流增益数据结构：高位在前.按照 BRG 的顺序发送，结构如下：

The current gain data is 15 bits in total. This product supports software settings for the output current of OUT, which includes 5 bits of current gain data and 1 bit of reserved bit data for each OUT B/R/G port. The structure of the 15bit current gain data is as follows: the high bit is sent in BRG order, with the high bit first

电流增益参数发送格式Current gain parameter sending format			
S0(保留位数据 Reserve bit data)	蓝灯 ( B )	红灯 ( R )	绿灯 ( G )
S0	GB4 , GB3 , GB2, GB1 , GB0	GR4 , GR3 , GR2,GR1 , GR0	GG4 , GG3 , GG2,GG1 , GG0

(1) S0 为待机指令位：芯片正常工作时，S0 默认发送0；芯片需进入待机休眠模式时，S0 发送1；

S0 is the standby command bit: When the chip is working normally, S0 defaults to sending 0; when the chip needs to enter sleep mode, S0 sends 1;

(2) GB4-GB0为OUTB端口电流增益数据，GR4-GR0为OUTR端口电流增益数据，GG4-GG0为OUTG端口电流增益数据，S0为保留位数据；GB4-GB0 is the current gain data of the OUTB port, GR4-GR0 is the current gain data of the OUTR port, GG4-GG0 is the current gain data of the OUTG port, and S0 is the reserved bit data;

OUT B/R/G 最大输出13mA，同时用户可通过改变电流增益数值设置其他电流值，参考电流值请参考下表：

The maximum output of OUT B/R/G is 13mA, and users can set other current values by changing the current gain value. Please refer to the following table for reference current values:

级数	电流增益current gain	IOUT(mA)	级数	电流增益current gain	IOUT(mA)
1	00000	0.4	17	10000	6.9
2	00001	0.8	18	10001	7.3
3	00010	1.2	19	10010	7.7
4	00011	1.6	20	10011	8.1
5	00100	2.0	21	10100	8.5
6	00101	2.4	22	10101	8.9
7	00110	2.8	23	10110	9.3
8	00111	3.2	24	10111	9.7
9	01000	3.6	25	11000	10.1
10	01001	4.0	26	11001	10.5
11	01010	4.5	27	11010	10.9
12	01011	4.9	28	11011	11.3
13	01100	5.3	29	11100	11.7
14	01101	5.7	30	11101	12.1
15	01110	6.1	31	11110	12.5
16	01111	6.5	32	11111	13

注：以上电流值仅为理论数据，实际电流可能有偏差，建议客户调节电流值以实测为准

Note: The above current values are only theoretical data, and there may be deviations in actual current. It is recommended that customers adjust the current values based on actual measurements

基于产品散热，此款产品电流建议最大使用为：4.9mA(12级) .Based on product heat dissipation, it is recommended to use a maximum current of 4.9mA (level 12) for this product;

## 14.应用电路原理图 Principles of Applied Circuits :

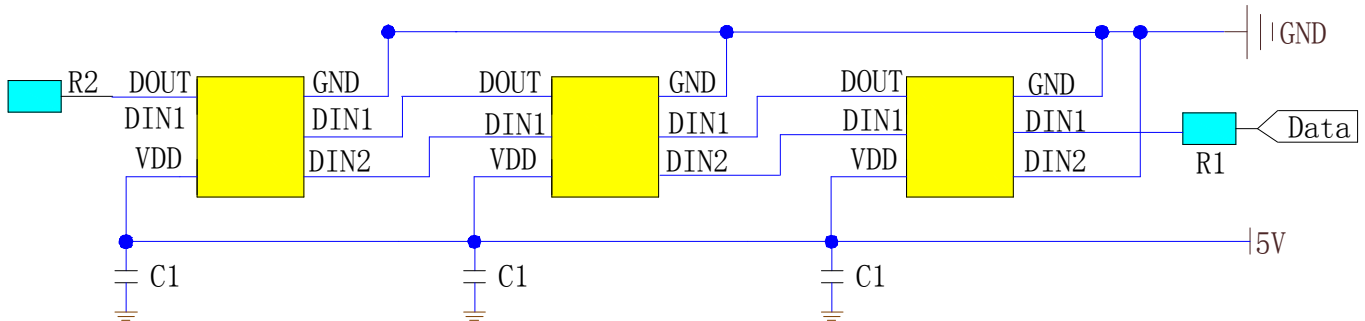

在实际应用电路中，为防止产品在测试时带电插拔产生的瞬间高压损伤IC内部信号输入输出引脚，应在信号输入及输出端串接保护电阻。此外，为了使各IC芯片间更稳定工作，各灯珠间的退偶电容则必不可少；

In practical application circuits, to prevent instantaneous high voltage damage to the internal signal input and output pins of the IC caused by live plugging and unplugging during testing, protective resistors should be connected in series at the signal input and output terminals. In addition, in order to ensure more stable operation between IC chips, the decoupling capacitance between each LED is essential;

应用一：用于软灯灯或硬灯条的，灯珠间传输距离短的，建议在信号输入输出端各串接保护电阻，即R1、R2约500欧，电阻数值以码元实际测试不畸变为准；

Application 1: For soft or hard light strips with short transmission distance between lamp beads, it is recommended to connect protective resistors in series at the signal input and output terminals, R1, R2, about 500 ohms, The resistance value shall be based on the actual testing of the symbol without distortion;

应用二：用于模组或一般异形产品，灯珠间传输距离长，因线材及传输距离不同，在信号两端串接的保护电阻会略有不同；以实际使用情况定；

Application 2: Used for modules or general shaped products. The transmission distance between lamp beads is long. Due to different wire materials and transmission distances, the protective resistance of the signal line connected in series at both ends will be slightly different; Based on actual usage;

## 15. 光电特性 Photoelectric characteristic :

焊盘温度与光通量输出的相对关系  
The relative relationship between pad temperature and luminous flux output

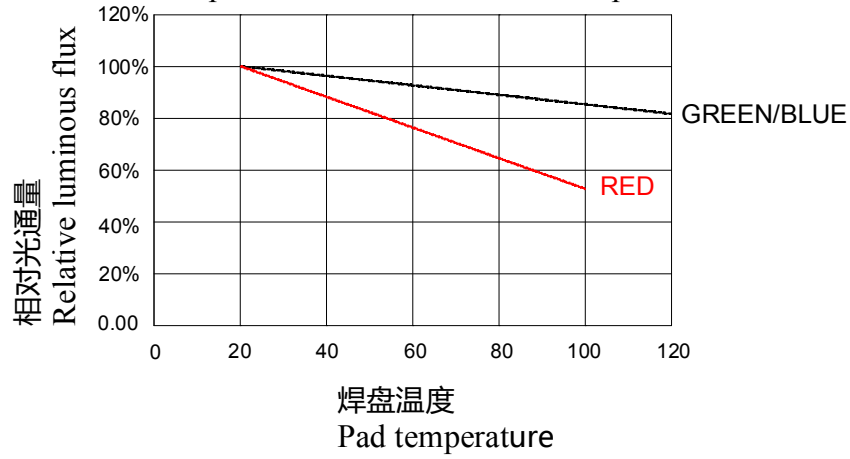

波长特性  
Wavelength characteristics

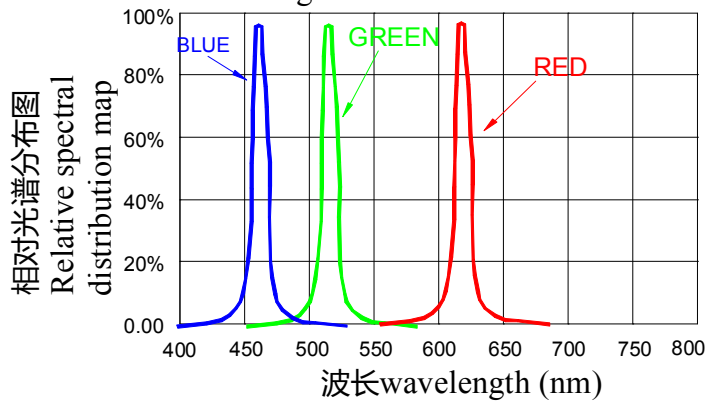

典型的辐射方向图 120°  
Typical radiation pattern 120°

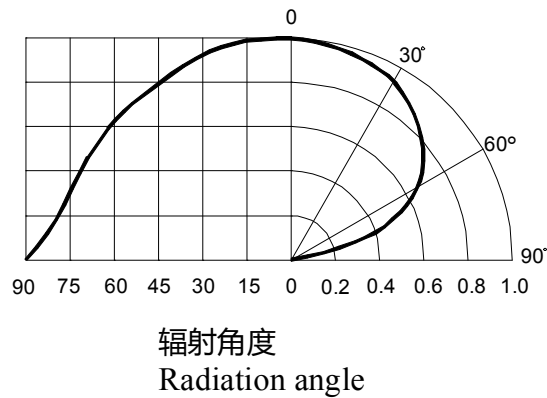

## 16. 包装标准 Packaging standards :

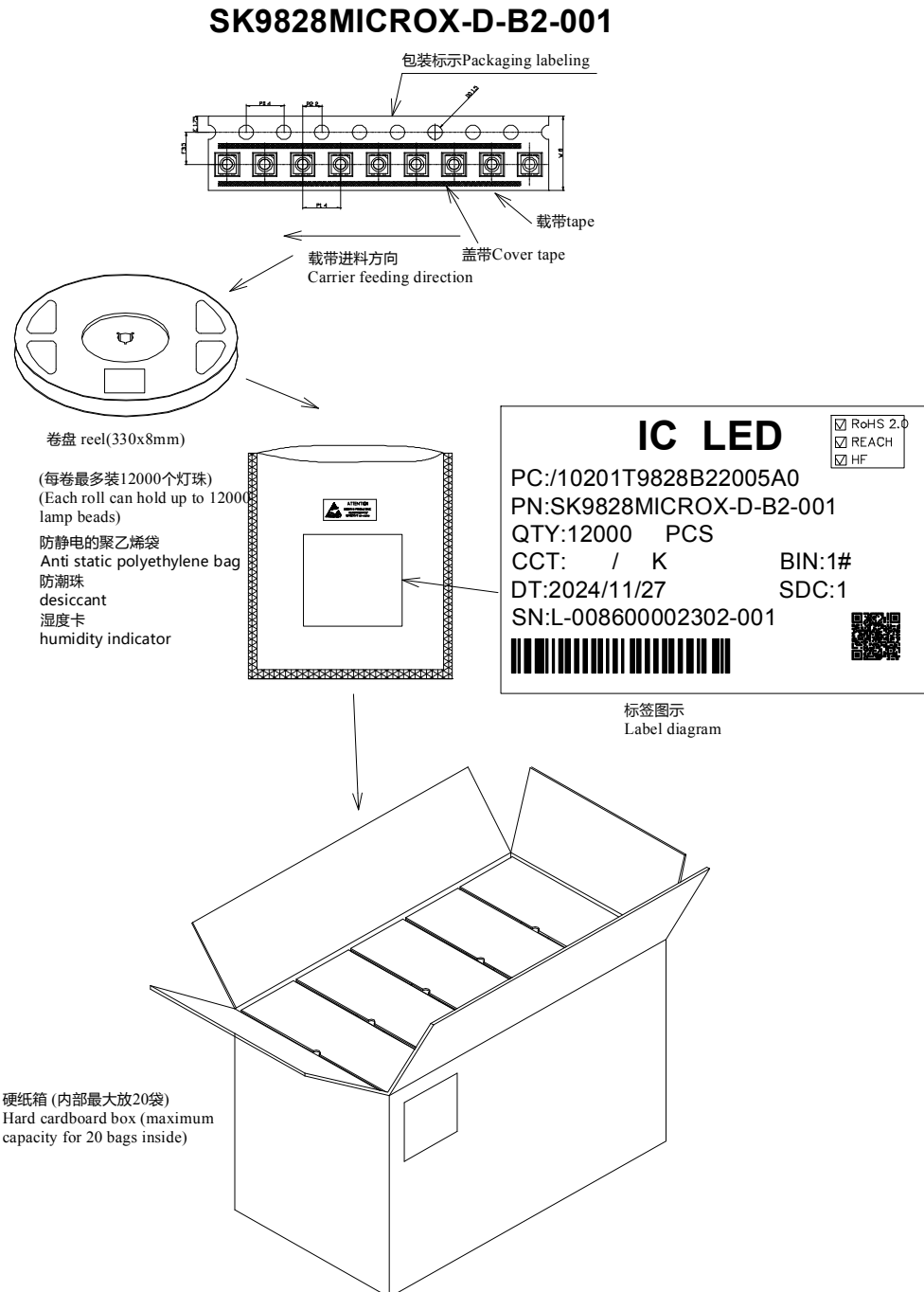

表面贴装LED采用卷盘包装，LED在用普通或防静电袋包装后再装在纸箱中。纸箱用于保护运输途中LED不受机械冲击，纸箱不防水，因此请注意防潮防水。

Surface mounted LEDs are packaged in rolls, and the LEDs are packaged in regular or anti-static bags before being packed in cardboard boxes. The cardboard box is used to protect the LED from mechanical impact during transportation. The cardboard box is not waterproof, so please pay attention to moisture-proof and waterproof.

# Shenzhen Normand Electronic Co.,Ltd

## 17. 可靠性测试 Reliability testing:

序号 Serial Number	实验项目 Pilot projects	实验条件 Experimental condition	参考标准 Reference standards	判断 Determine
1	冷热冲击 Thermal Shock	100 ± 5°C ~ -40°C ± 5°C 15min~15min 100cycles	MIL-STD-202G	0/22
2	高温储藏 High temperature storage	Ta= +100°C 1000hrs	JEITA ED-4701 200 201	0/22
3	低温储藏 Low temperature storage	Ta= -40°C 1000hrs	JEITA ED-4701 200 202	0/22
4	高温高湿储藏 High temperature and high humidity storage	Ta=60°C RH=90% 1000hrs	JEITA ED-4701 100 103	0/22
5	温度循环 Temperature cycling	-40°C~25°C~100°C~25°C 30min~5min~30min~5min 100 cycles	JEITA ED-4701 100 105	0/22
6	耐焊接热 Resistance to Soldering Heat	Tsld = 260°C, 10sec. 2 times	JEITA ED-4701 300 301	0/22
7	常温寿命测试 Normal temperature life test	25°C, IF: Typical current , 1000hrs	JESD22-A 108D	0/22

## 失效判定标准 Failure criteria:

项目 Project	符号 Symbol	测试条件 Test conditions	判断标准Judgment criteria	
			最小值 Minimum value	最大值 Maximum value
发光强度 Intensity	IV	DC=5V,规格典型电流 DC=5V, Typical current specification	初始数据X0.7 Initial data X0.7	---
耐焊接热 Resistance to Soldering Heat	---	DC=5V,规格典型电流 DC=5V, Typical current specification	无死灯或明显损坏 No dead lights or obvious damage	

