

Product Specification

Document number: NMD-SPC-SK6805-EC3210F
Product model: SK6805-EC3210F
Product description: 3.2x1.0x1.08mm Type 0.1Watt Power Embedded
(MSL: 4)
Version number: 01
Time: 2021-03-29



CONTENTS

| | |
|---|----|
| 1、 Product overview..... | 4 |
| 2、 Main Application Field..... | 4 |
| 3、 Description..... | 4 |
| 4、 Mechanical Dimensions..... | 5 |
| 5、 PIN configuration..... | 5 |
| 6、 Recommended dimensions for PCB products..... | 5 |
| 7、 General description of product naming..... | 6 |
| 8、 Electrical parameters..... | 6 |
| 9、 Electrical/Optical Characteristics..... | 6 |
| 10、 IC The electrical parameters..... | 7 |
| 11、 Switching characteristics..... | 7 |
| 12、 The data transmission time | 8 |
| 13、 Timing waveform..... | 8 |
| 14、 The method of data transmission..... | 9 |
| 15、 The data structure of 24bit..... | 9 |
| 16、 The typical application circuit..... | 9 |
| 17、 Standard LED Performance Graph..... | 10 |
| 18、 Packaging Standard..... | 11 |
| 19、 Reliability Test..... | 12 |

1. Product Overview :

SK6805-EC3210F is an embedded control LED light source, which includes intelligent digital, digital interface, data latching, signal shaping and amplifying driver, power supply voltage stabilizing circuit, built-in constant current circuit, high precision RC oscillator, the output drive uses the patent PWM technology, effectively guarantees the pixel point inside the light color high consistency. The data protocol adopts the communication method of Unipolar Return Code. After the Pixel is reset on the power, the DIN terminal receives the data transmitted from the controller. The first 24 bit data sent is extracted by the first pixel and sent to the Pixel, the rest of the data is amplified by the internal shaping, then the data is rotated through the DO port, and the output is sent to the next cascaded pixels, and the signal is reduced by 24bit for each pixel. Pixel, the use of automatic shaping forwarding technology, so that the number of the Pixel cascade is limited by the signal transmission, only limited by the signal, the transmission speed requirements.

2. Main features

- Easy To Design
- Easy To Build
- Easy To Program

3. Description:

- Chip SMD internal integrated high quality external control line serial cascade constant current IC;
- control circuit and the RGB chip in EC3210 components, to form a complete control of pixel, color mixing uniformity and consistency;
- built-in data shaping circuit, a pixel signal is received after wave shaping and output waveform distortion will not guarantee a line;
- The built-in power on reset and reset circuit, the power does not work;
- gray level adjusting circuit (256 level gray scale adjustable);
- red drive special treatment, color balance;
- line data transmission;
- plastic forward strengthening technology, the transmission distance between two points over 10M;
- Using a typical data transmission frequency of 800 Kbps, when the refresh rate of 30 frames per sec

4. Mechanical Dimensions:

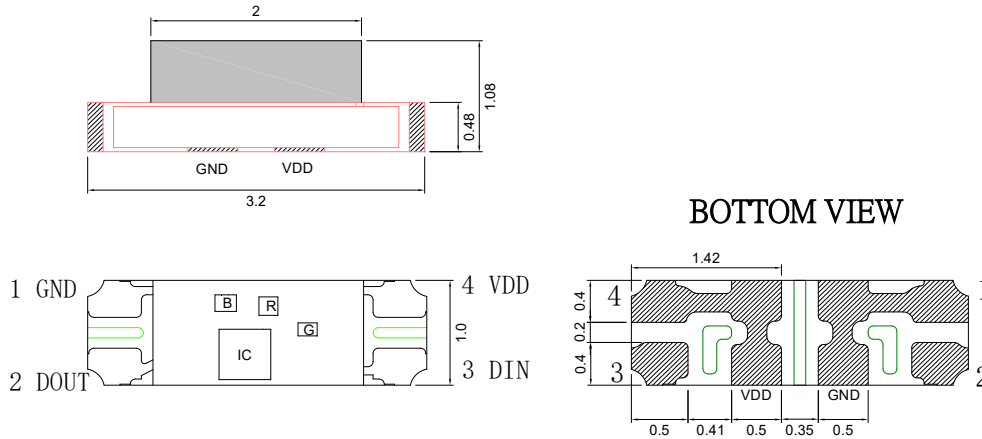

- Notes:**
1. All dimensions are in millimeters.
 2. Tolerance is $\pm 0.05\text{mm}$ unless otherwise noted

5. PIN configuration:

| NO. | Symbol | Function description |
|-----|--------|----------------------------|
| 1 | GND | Ground |
| 2 | DOUT | Control data signal output |
| 3 | DIN | Control data signal input |
| 4 | VDD | Power supply LED |

6. Recommended dimensions for PCB:

Top patch suggested pad

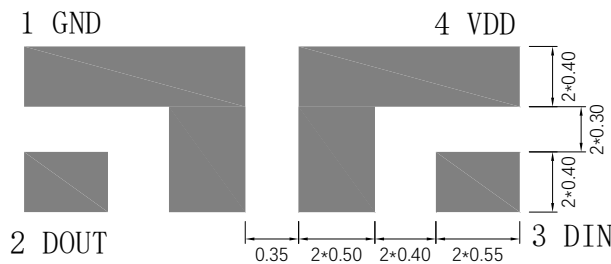

Top mounting diagram

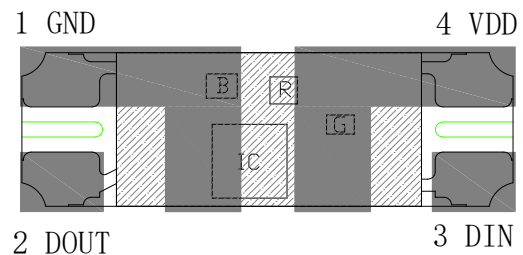

Side patch suggested pad

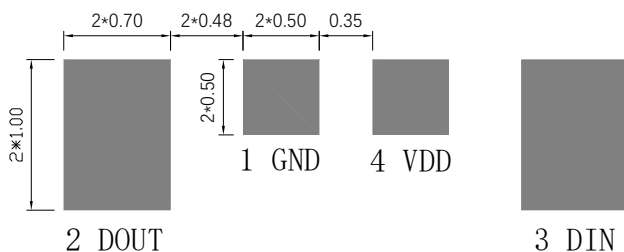

Sketch map of side mounting

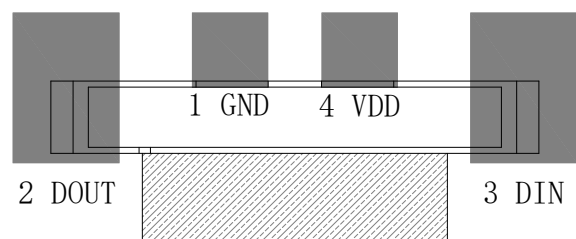

7. General description of product naming

SK 6805 - EC3210 F

① ② ③ ④

| ① | ② | ③ | ④ |
|--|---|---|---------------------|
| series | IC series and current code | Package shape | Lens shape |
| By default, RGB chip is integrated with IC | Refers to 68 series IC 6805: refers to 5mA current version | 3.2x1.0x1.48mm PCB bracket packaging | F:means square Lens |

8. Electrical parameters (Ta=25°C,VSS=0V) :

| Parameter | Symbol | Range | Unit |
|----------------------|-----------|--------------|------|
| Power supply voltage | VDD | +3.7~+5.5 | V |
| Logic input voltage | V_{IN} | -0.5~VDD+0.5 | V |
| Working temperature | Topt | -40~+80 | °C |
| Storage temperature | Tstg | -40~+80 | °C |
| ESD pressure(HBM) | V_{ESD} | 2K | V |
| ESD pressure(DM) | V_{ESD} | 200 | V |

9. Electrical/Optical Characteristics:

| Color | SK6805-EC3210R 5mA | |
|-------|-------------------------|----------------|
| | Dominate Wavelength(nm) | Luminance(mcd) |
| Red | 620-630 | 80-160 |
| Green | 520-535 | 240-450 |
| Blue | 460-475 | 60-120 |

10. IC The electrical parameters (unless otherwise specified, TA=-20 ~ +70 °C, VDD=4.5 ~ 5.5V, VSS=0V):

| Parameter | Symbol | Min | Typical | Max | Unit | Test conditions |
|---------------------------------|--------|---------|---------|---------|------|-----------------|
| The chip supply voltage | VDD | --- | 5.2 | --- | V | --- |
| The signal input flip threshold | VIH | 0.7*VDD | --- | --- | V | VDD=5.0V |
| | VIL | --- | --- | 0.3*VDD | V | |
| The frequency of PWM | FPWM | --- | 4.0 | --- | KHZ | --- |
| Static power consumption | IDD | --- | 0.25 | --- | mA | --- |

11. Switching characteristics (VCC=5V Ta=25 °C):

| Parameter | Symbol | Min | Typical | Max | Unit | Test conditions |
|----------------------------------|--------|-----|---------|-----|------|---|
| The speed of data transmission | fDIN | --- | 800 | --- | KHZ | The duty ratio of 67% (data 1) |
| DOUT transmission delay (Note 4) | TPLH | --- | 100 | --- | ns | The load capacitance of dout port to ground is 30pf, Signal transmission delay from DIN to dout |
| | TPHL | --- | 100 | --- | ns | |
| DOUT Conversion time (Note 5) | TLH | --- | 15 | --- | ns | The load capacitance of dout port to ground is 30pf |
| | TTHL | --- | 24 | --- | ns | |
| IOUT Rise/Drop Tim (Note 6) | Tr | --- | 200 | --- | ns | Iout = 5mA, out R / g / B port series connection 200 Ω electricResistance to VDD, load capacitance to ground 30pF |
| | Tf | --- | 280 | --- | ns | |

Note 4、Note 5、Note 6 : As shown in the figure below

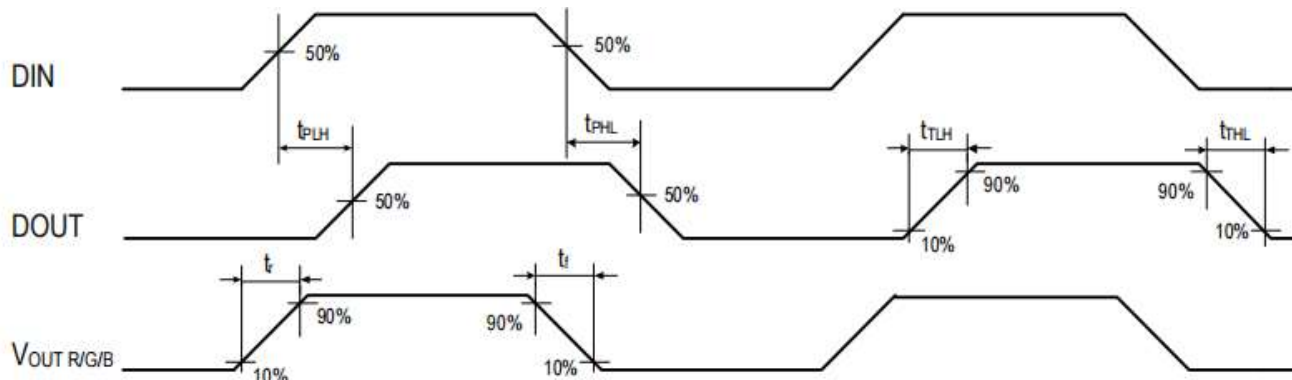

12. The data transmission time :

| Name | | Typical value | Tolerance range | Unit |
|------|----------------------------|---------------|-----------------|------|
| T | Code period | 1.2 | -- | μs |
| T0H | 0 code, high level time | 0.3 | ±0.05 | μs |
| T0L | 0 code, low level time | 0.9 | ±0.05 | μs |
| T1H | 1 code, high level time | 0.9 | ±0.05 | μs |
| T1L | 1 code, low level time | 0.3 | ±0.05 | μs |
| Trst | Reset code, low level time | > 200 | -- | μs |

1. The protocol uses a unipolar zeroing code. Each symbol must have a low level. Each symbol in this protocol starts with a high level. The high time width determines the "0" or "1" code. .
2. When writing programs, the minimum symbol period is 1.2μs.
3. The high time of "0" code and "1" code should be in accordance with the stipulated range in the above table. The low time requirement of "0" code and "1" code is less than 20μs.

13. Timing waveform:

Input code:

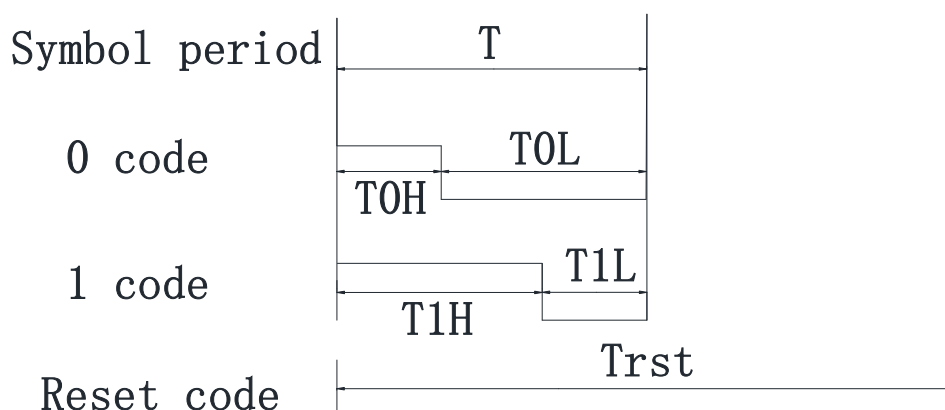

Connection mode:

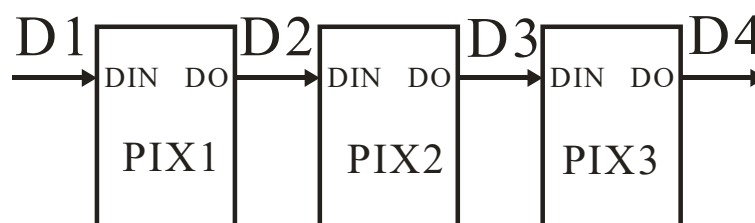

14. The method of data transmission:

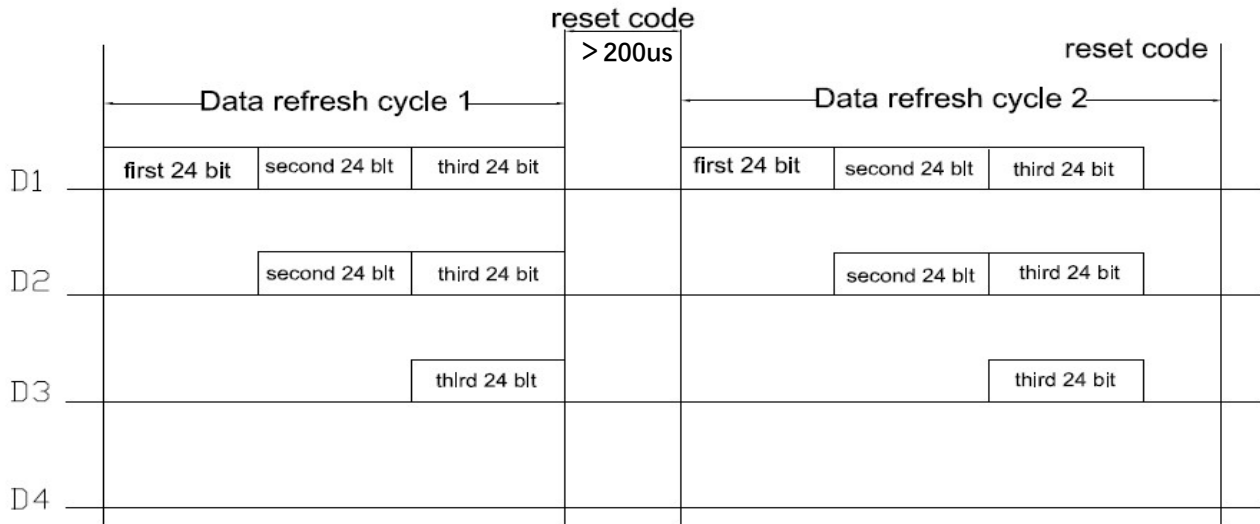

Note: the D1 sends data for MCU, D2, D3, D4 for data forwarding automatic shaping cascade circuit.

15. The data structure of 24bit:



Note: high starting, in order to send data (G7 - G6 -B0)

16. The typical application circuit:

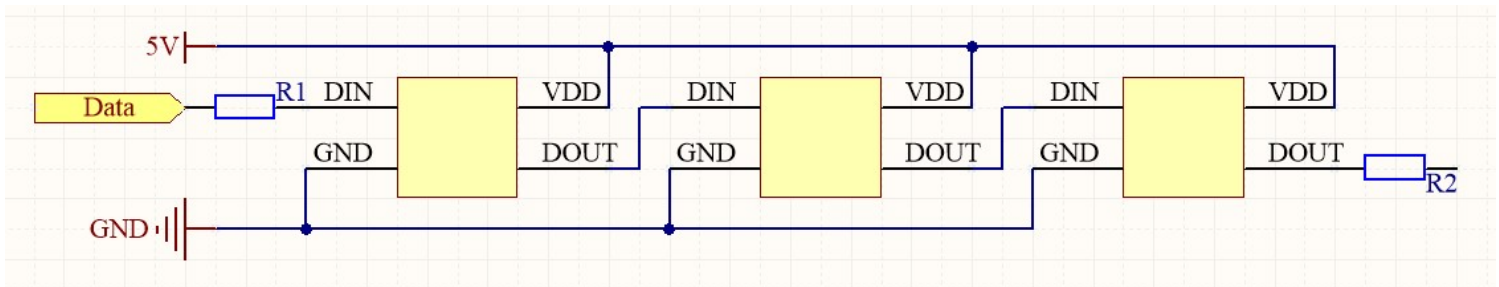

In the practical application circuit, the signal input and output pins of the IC signal input and output pins should be connected to the signal input and output terminals. In addition, in order to make the IC chip is more stable, even the capacitance between beads is essential back;

Application: used for soft lamp strip or hard light, lamp beads transmission distance is short, suggested in signal in time the clock line input and output end of each connected in series protection resistors, R1 of about 500 ohms.

Application: for module or general special-shaped products, lamp beads transmission distance is long, because of different wire and transmission distance, in the signal in time clock at both ends of the line on grounding protection resistance will be slightly different; to the actual use of fixed;

17. Standard LED Performance Graph:

Thermal Pad Temperature vs. Relative Light Output

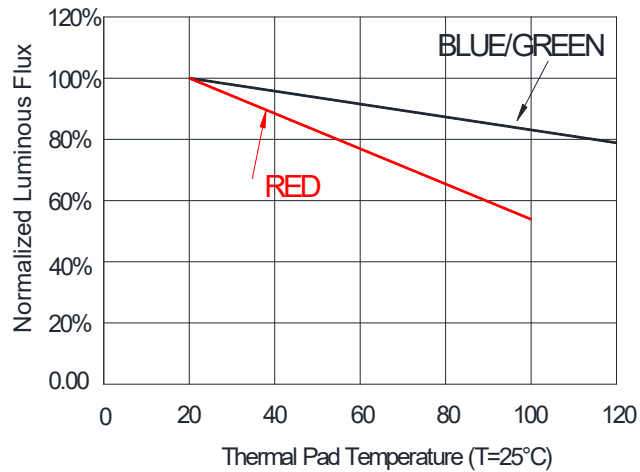

Wavelength Characteristics

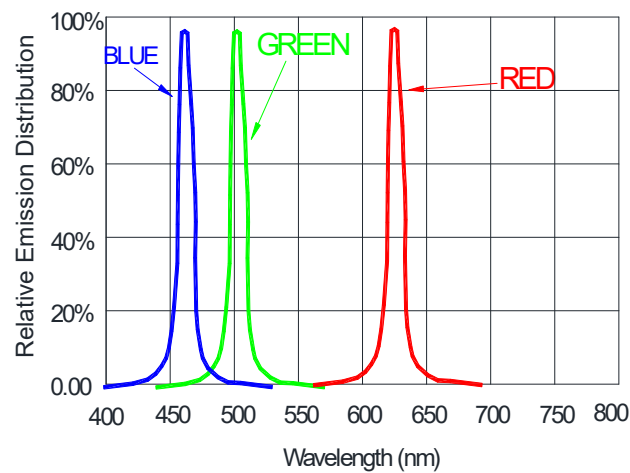

Typical Radiation Pattern 160°

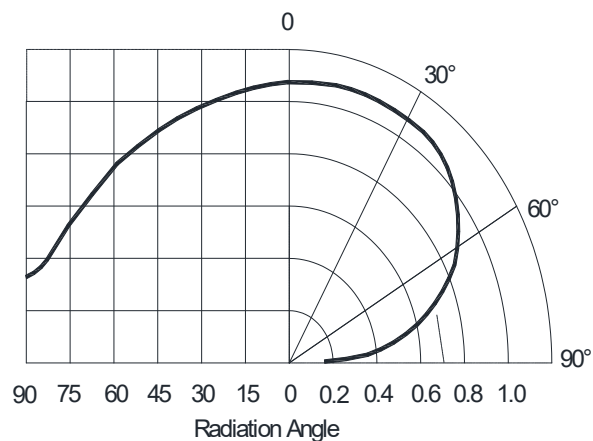

18. Packaging Standard:

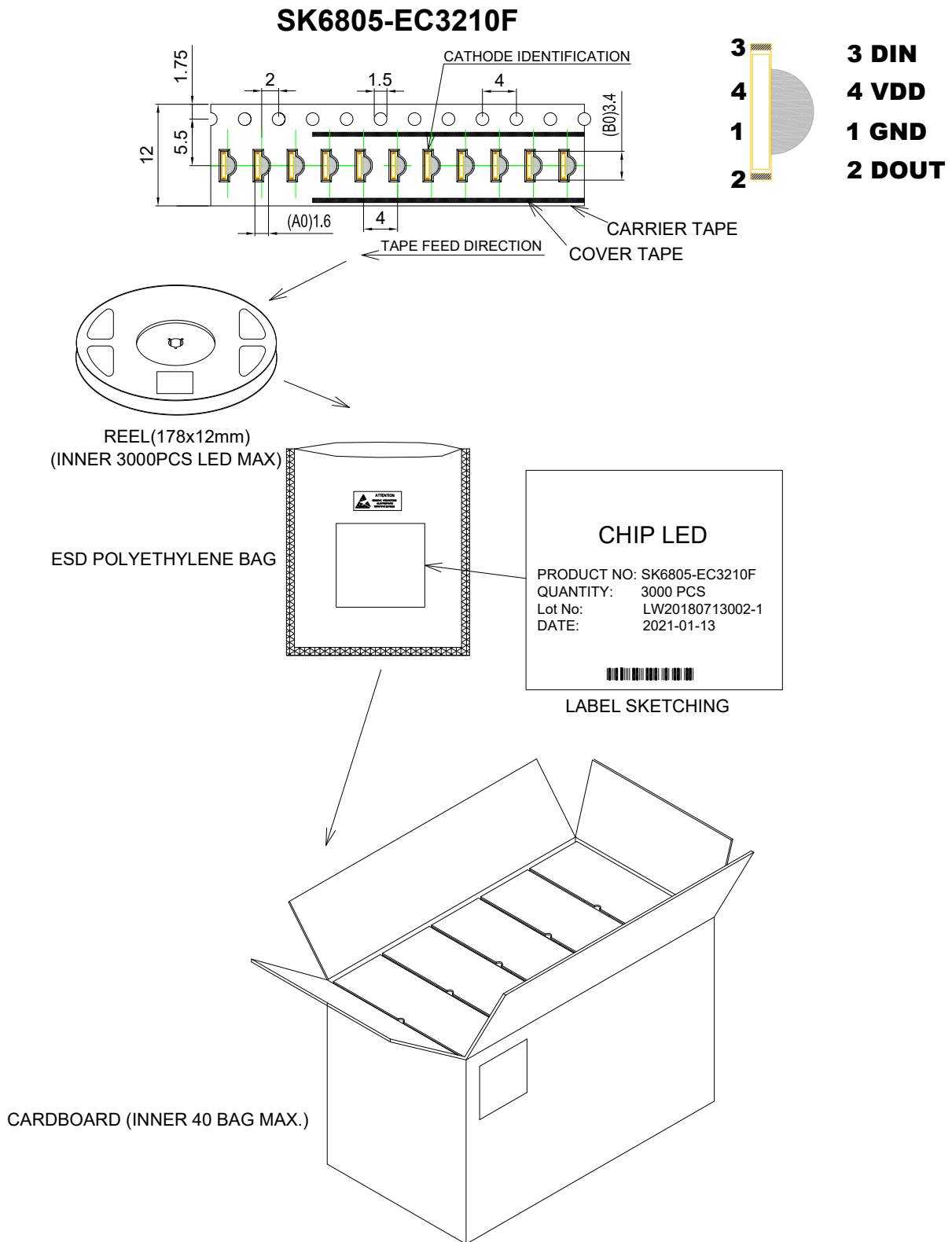

The reel pack is applied in SMD LED. The LEDs are packed in cardboard boxes after packaging in normal or anti-electrostatic bags. cardboard boxes will be used to protect the LEDs from mechanical shocks during transportation. The boxes are not water resistant and therefore must be kept away from water and moisture.

19. Reliability Test :

| NO. | Test item | Test Conditions | Reference | Criterion |
|-----|--|---|--------------------------|-----------|
| 1 | Thermal Shock | -20°C*15min~80°C*15min 100cycles | MIL-STD-202G | 0/64 |
| 2 | High Temperature Storage | Ta= 100°C 1000hrs | JEITA ED-4701 200 201 | 0/64 |
| 3 | Low Temperature Storage | Ta= -40°C 1000hrs | JEITA ED-4701 200 202 | 0/64 |
| 4 | High Temperature High Humidity Storage | Ta=60°C RH=90% 1000hrs | JEITA ED-4701 100 103 | 0/64 |
| 5 | Temperature Cycle | -20°C~25°C~80°C~25°C 30min~5min~30min~5min 100 cycles | JEITA ED-4701 100 105 | 0/64 |
| 6 | Resistance to Soldering Heat | Tsld = 260°C, 10sec. 2times | JEITA ED-4701 300 301 | 0/64 |
| 7 | Room temp Life Test | Ta<35°C, IF:Typical current, 3000hrs | JESD22-A 108D | 0/22 |

Criteria for Judging the Damage:

| Item | Symbol | Test Condition | Limit | |
|------------------------------|--------|------------------------|----------------------------------|-----|
| | | | Min | Max |
| Luminous Intensity | IV | DC=5V, Typical current | Init. Value*0.7 | --- |
| Resistance to Soldering Heat | --- | DC=5V, Typical current | No dead lights or obvious damage | |